

P2000B / P2000BS Indicator

Technical Manual

CE



Contents

1. Main Data	1
2. Main Features	1
3. Construction	2
4. Operation Keys Instruction	4
5. Use	5
5.1. Preparation	5
5.2. Power-on operation	5
5.3. Zero-setting	6
5.4. Deducting tare	6
5.5. Accumulation	6
5.6. Display converting for gross weight and net weight	8
5.7. RS-232C output	8
5.8. Ticket printing output	9
5.9. Unit switch	10
5.10. Digit Input	11
6. Use Guide	11
7. Data Setting and Calibration	12
7.1. Entering main directories	13
7.2. Entering subdirectories	13
7.3. Calibration	15
7.4. Flow chart for setting and calibraton	18

Notice to Users

You are welcome to use Pioneer series indicators. This indicator possesses such features as fashionable appearance, cordial operation-interface, high-resolution, reliable measuring performance and so on. Please read this manual carefully before you operate the indicator so that you might fully enjoy the convenience from it. We reserve the right to make amendments to the specifications of our products.

Note: Both HST and Pioneer are the registered trade marks of our company.

1. Main Data

- 1.1. Zero-load signal input range: 0mV ~ 8mV
- 1.2. Zero point temperature drift $\leq 0.15\mu$ V/°C
- 1.3. Sensitivity temperature drift ≤ 10 ppm/ °C
- 1.4. A/D conversion resolution ratio: 280000
- 1.5. Display resolution ratio: 20000
- 1.6. A/D conversion rate: 3 ~ 10T/S
- 1.7. Accuracy class: **III**
- 1.8. Non-linearity: $\leq 0.01\%$ F•S
- 1.9. Load cell exciting power: DC8V, driving 4 load cells of 350 Ω
- 1.10. Operation temperature: 0 ~ 40 °C
- 1.11. Storage environment temperature: -25 °C ~ 55 °C
- 1.12. Relative humidity: $\leq 90\%$ (no condensation)
- 1.13. Min. display value: 1 / 2 / 5 available
- 1.14. Display style: 6-digit 0.56-inch 7-segment LED
- 1.15. Thirteen Max. capacities optional: 6kg (12lb) ~ 10000kg (20000lb)
- 1.16. Baud rate for data output available: 600, 1200, 2400, 4800 and 9600
- 1.17. Power supply: AC220V 50Hz (AC240V, 120V or 110V optional)
- 1.18. Dimensions (L x H x W) P2000B: 250 x 180 x 130 mm
P2000BS: 290 x 210 x 130 mm
- 1.19. Dead weight (kg) P2000B: ≤ 1.1
P2000BS: ≤ 1.7

2. Main Features

- 2.1. Up to external graduation number of 20000e
- 2.2. Complete keyboard calibration
- 2.3. Auto zero tracking
- 2.4. Full range tare
- 2.5. Overload indicating
- 2.6. Weight and times accumulating
- 2.7. Display converting for gross weight and net weight
- 2.8. Display converting for counts and weight

- 2.9. Unit switch
- 2.10. Two calibration methods: Fixed point and arbitrary point calibrating
- 2.11. Extension display (i.e. internal counter display function)
- 2.12. RS-232C output (option)
- 2.13. Many installation modes P2000B: Column-mounted and table version
P2000BS: Wall-mounted and table version

3. Construction

3.1. Structure diagram

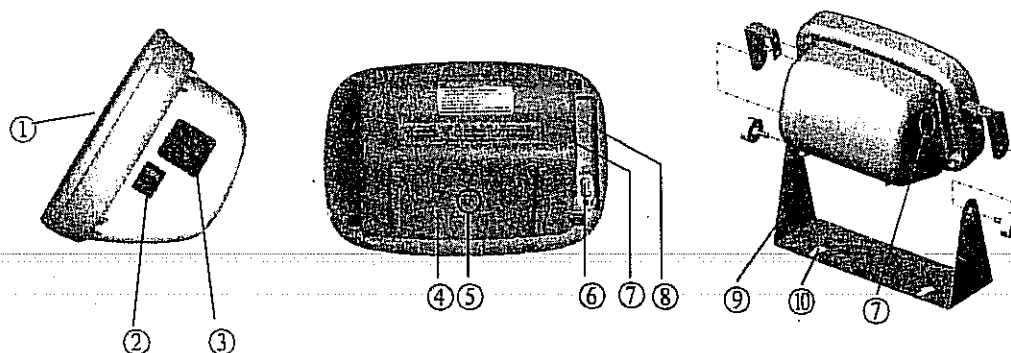

Figure 1: Appearance

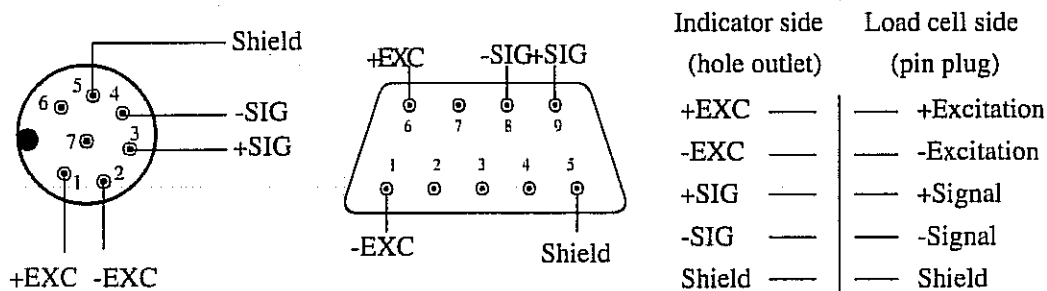

Figure 2: Input outlet for load cell signal (4-wire system)

- ① Indicator front cover (containing operation panel)
- ② Power switch (when it is set at "I", the power is on) — possibly not to be mounted
- ③ AC input outlet or power adapter input outlet, with built-in cartridge fuse (if the users demand AC input, capacity of the fuse accompanied is 0.3A and 2A when the power adapter is used)
- ④ Screw holes used for connecting indicator with column joint
- ⑤, ⑥ One of them will be mounted with a load cell input outlet (D-type 9-core or 7-core outlet made of metal)
- ⑦, ⑧ One of them will be mounted with a RS-232C output outlet (D-type 25-core or 3-core outlet made of metal)
- ⑨ Stainless steel support (only P2000BS)
- ⑩ Holes used for hanging indicator

3.2. Panel

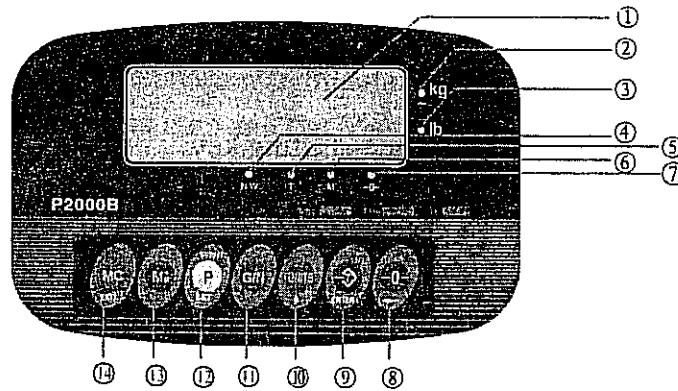

Figure 3: Panel diagram

- ① 6-digit LED digital tube
- ② Indicating light for “kg” weight unit and steady weighing
- ③ Indicating light for “lb” weight unit and steady weighing
- ④ Indicating light for net weight
- ⑤ Indicating light for tare storing
- ⑥ Indicating light for accumulating
- ⑦ Indicating light for zero position
- ⑧ Zero-setting key
- ⑨ Tare key
- ⑩ Unit switch key
- ⑪ Gross weight /net weight converting key
- ⑫ Printing key
- ⑬ Accumulating and display calling key
- ⑭ Accumulation clearing key

3.3. Cursors and their meanings

6 LED prompting cursors are set for the indicator (2 of the cursors is of compound use). See the following for their names and meanings.

Table 1

Cursor Symbol	Meaning
→ 0 ←	It appears when the weight is within 1/4 d (zero position)
T	It appears when the deducting-tare operation is effective (there is tare in storage)
M ⁺	It appears when there is accumulation in memory
N.W.	It appears when the display value is net weight
kg (~)	It appears when the weight unit selected is “kilogram” and after the weighing is stable
lb (~)	It appears when the weight unit selected is “pound” and after the weighing is stable

4. Operation Keys Instruction

4.1. Zero and place-shifting key

a. Under weighing state, when the weight displayed is not more than 2% of Max. weighing capacity, you can press this key to make the display return to zero. While pressing this key repeatedly, you can make the display of not more than 5% Max. capacity return to zero. At the same time, "→ 0 ←" cursor on the LED screen is on..

b. Under calibrating state, this key is used for selecting digit place. When this key is used, the selected digit is moved to the left and the digit at this place will flash.

4.2. Tare and confirmation key

a. Under weighing state, when the weight loaded on the scale platform is not more than Max. Capacity plus 9e ("e" refers to division value), you can make the display return to zero by pressing this key, and the cursor "T" on the screen will appear. At this time if you remove the article from the scale platform, the screen displays a negative value. If you press this key again, the display returns to zero and the cursor "T" disappears.

b. Under calibrating and setting state, this key is used for confirming the present state (result) and prompting the next step to go on to.

4.3. Unit converting and digit increasing key

a. If you press this key once according to the setup content on F1.1, the weight unit will convert between "kg" and "lb".

b. Under calibrating and setting, if you press this key, you can make the selected digit change in 0 → 1 → 2 ...9 → 0 sequence.

4.4. Gross / net weight converting key

This key is used for converting the display value between gross weight and net weight.

4.5.  Printing key

- a. When you press this key under weighing state, the printing command character will appear in the serial data to be sent.
- b. You also need to use this key during calibrating.

4.6.  Storing and display calling key

- a. You can accumulate the displaying value by pressing this key. While accumulating the indicator will first display the accumulated time and then displays the accumulated weight value divided into 2 parts in 2 times.
- b. You can also press this key to call the accumulated value for display.

4.7.  Clearance key

- a. You can clear the accumulated value by pressing this key. And after the accumulation is cleared, the cursor indicating "M+" disappears.
- b. Under calibrating and setting states, you can press this key to exit.

5. Use

5.1. Preparation

Before power-up, you should check whether the wire-connection of load cell signal input is correct (see Figure 2). 4-wire-system input mode is usually used for the indicator. If using 6-wire-system input mode, you must short-connect positive excitation and positive feedback and short-connect negative excitation and negative feedback, and then start working. Except the above-mentioned, before starting you should also confirm whether the power supply is in accordance with the indicator's requirement.

5.2. Power-on operation

Insert power plug, the indicator first displays the edition number, then displays the Max. capacity and then carry through self-checking from "9" to "0" successively. If its connection is correct and zero position is normal, the indicator will display "0".

5.3. Zero-setting operation

When the weighing is under 2%F•S and if you press [→ 0 ←], the indicator

displays “0”. And the repeated zero-setting range is 5%F•S for the indicator. When the cursor indicating “T” is on, you can not carry through zero-setting operation.

5.4. Deducting tare operation

5.4.1. When the article is loaded on the scale platform and if you want to regard its weight as tare to be deducted, press [→ T ←], the indicator will display “0” and the cursor indicating “T” will be on. And continual deducting-tare value can’t exceed the Max. capacity.

5.4.2. When the indicator display “0” and the cursor indicating “T” is on, if you press [→ T ←], the cursor “T” will disappear.

5.4.3. See the following table for negative tare appearing and clearing.

Table 2

Steps	Display	Meaning
place the article on the platform	0.10	Which means the article’s weight is 0.1kg (can be regarded as tare).
Press [→ T ←]	0.00	The tare has been deducted, and at this time the cursor indicating “T” appears.
Remove the article	-0.10	The indicator displays the tare value (anegative value).
Press [→ T ←] again	0.00	The negative tare is cleared and the cursor indicating “T” disappears.

5.5. Accumulation

While carrying through weighing every time, you can accumulate the weighing result by pressing [M⁺]. And you can also clear the accumulated values in memory by pressing [MC].

5.5.1. Accumulating

After the weighing is steady (the article is loaded on the scale platform), press [M⁺] once, the weight value for this weighing is accumulated, and the indicator will first display the total accumulated times and then display the total accumulated weight in 2 seconds. Since the weight value to be accumulated may exceed 6- figure digit (the decimal system), the accumulated value is divided into 2 parts for display, and the indicator first dis

plays $\boxed{H X_8 X_7 X_6 X_5}$ and then displays $\boxed{L X_4 X_3 X_2 X_1 X_0}$ in 2 seconds. $X_4 X_3 X_2 X_1 X_0$ indicates the low 5-figure digit of the accumulated value and $X_8 X_7 X_6 X_5$ refers to the high 4-figure digit of the accumulated value. The actual accumulated value should be $X_8 X_7 X_6 X_5 X_4 X_3 X_2 X_1 X_0$. Of course, the high-figure digit may be with "0" or all "0", and the ineffective "0" at high figure will be concealed. But when the digits at high figure are all "0", "0" at the last place on high-figure will be display, i.e. $\boxed{H 0}$.

When there is an accumulated value in memory, the cursor indicating "M+" will appear. The Max. accumulation times for the scale (indicator) can reach 100 times every time due to its memory limit. When the times exceeds 100, the accumulation operation is not responded and the indicator displays \boxed{OF} , and at this time the indicator will remain the display for 3 seconds and then return to normal display state. Under this case you can carry through accumulation operation only after clearing its memory.

5.5.2. Accumulating repeatedly

To compare with the last (or first) accumulation, the next (or second) accumulation must be carried through after unloaded (i.e. after the indicator returns to zero). And you only need to press [M+] once for accumulation every time.

5.5.3. Accumulated value displaying

a. While the article is still on the scale platform, see Item 5.4.1 for the display method of the accumulated times and the accumulated weight value. Attention please: After pressing [M+] once, if you don't remove the article from the scale platform, at this time the function of [M+] is the same as [MR], only for viewing previous accumulated value and not for any accumulation operation.

b. Under zero-load state (i.e. when the indicator displays "0"), you can press [MR] to call the accumulated times and weight value up to now for display. In the same way, the indicator will first display total times and then total weight value dividing into 2 parts in 2 seconds as Item 5.4.1.

Note: The [M+] and the [MR] is the same key for this indicator.



5.5.4. Accumulated value clearing

You can clear all the accumulation values (the times and the weight value) in memory by pressing [MC]. When you press [MC] and at the same time **CLE** is displayed, which means the operation is responded. At this time the accumulated values that is up to present is cleared and the cursor indicating “M+” disappears. At the same time the indicator displays **CLE** and then returns to normal display state in 3 seconds.

5.6. Display converting for gross weight and net weight

Under weighing state, you can press [G/N] to convert the display value between gross weight and net weight. When the indicator displays the net weight, the cursor “N.W.” appears. If the cursor “N.W.” is not on, the displaying value is the gross weight.

5.7. RS-232C output

5.7.1. The D-type 25-core outlet (Number ⑧ on Figure 1) or 3-core metal outlet (Number ⑦ on Figure 1) is used for RS-232C hardware interface, the outlet is mounted on back housing of the indicator. See the following drawing for details:

5.7.2. The serial data (ASCII code) is transmitted in continuous mode by MCS-51 way 1, every group of data has 17 frames including 1 frame of start character (02), 3 frames of state mark, 6 frames of data displaying, 6 frames of tare data and 1 frame of enter, as follows:

STX State A State B State C Display value Tare value Enter

STX: Start character, 02H

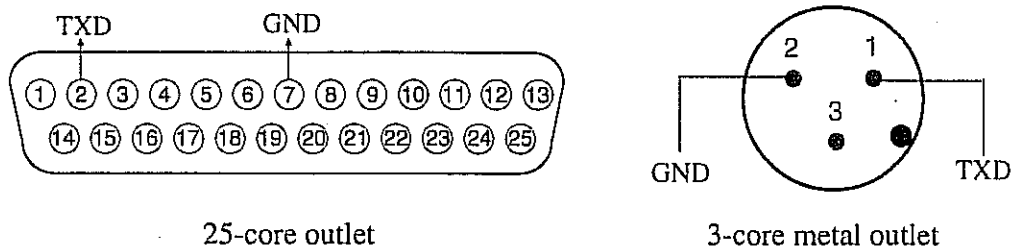

Figure 4: Interface of serial signal output

State A: Control character for decimal point (D7 refers to verification bit)

	D7	D6	D5	D4	D3	D2	D1	D0	Decimal point place
Verification bit	0	1	0	1	0	1	0	0	Without decimal point
	0	1	0	1	0	1	1	1	1-digit decimal 0.0
	0	1	0	1	1	0	0	0	2-digit decimal 0.00
	0	1	0	1	1	0	1	1	3-digit decimal 0.000
	0	1	0	1	1	1	1	0	4-digit decimal 0.0000

State B: Comprehensive control character (D7 refers to verification bit)

D7	Verification bit	
D6	0	
D5	1	
D4	1	
D3	Dynamic mark bit	D3=0, stability; D3=1, non-stability (dynamic)
D2	Overload mark bit	D2=0, normality; D2=1, overload
D1	Positive and negative mark bit D1=0, positive number; D1=1, negative number	
D0	Gross weight and net weight mark bit D0=0, gross weight; D0=1, net weight	

State C: Output control character (D7 refers to verification bit)

	D7	D6	D5	D4	D3	D2	D1	D0	Output content (after pressing [P])
Verification bit	0	1	0	0	0	0	0	0	Blank, without printing order
	0	1	0	1	0	0	0	0	(

When F1.4=2, if you press[P] in weighing state, the command character "(" will appear in the output data.

5.7.3. Every frame consists of 10 digits. The first is start bit, 0. The ninth is stop bit, 1. One of the other eight is correction bit and the other seven are all data bits (from low to high), the format is as follows:

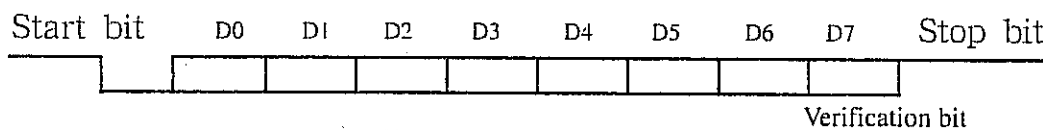

Figure 5: Frame format

5.8. Ticket printing output

It is effective only when the version number is equal to or more than REV.1.3

① Option of the indicator data

This indicator can be matched to EPSON TM-U295 micro-printer. In order to be matched to the printer, we should set the data of the indicator F1.4=3 and F1.3 is chosen the baud rate consistent to the printer. At this moment, if you press [P] key, the printer will print the ticket in the ticket mode as following:

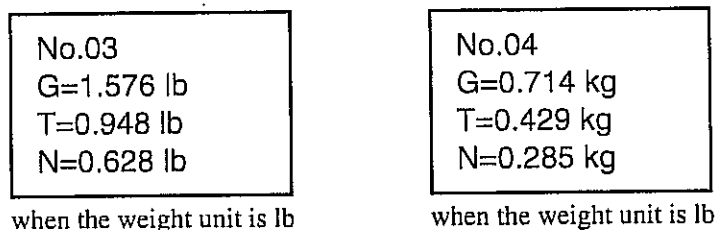

Figure 6: Ticket Printing Mode

② Connection between the indicator and the printer

If there is one cable provided together with printer, connect one end of the cable to D-type 25-core pin plug of the printer and the other end to the D-type 25-core hole or 5-core metal plug of the indicator as following:

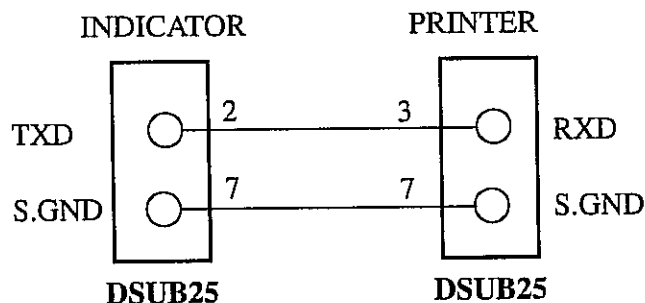

Figure 7: Connection Map (the cable should be prepared by the user)

③ Explanation about the printing format

- a. The printer will not print if the net weight is a negative value
- b. The number varies from 0~99. When it exceeds 99, it will back to 0 automatically

5.9. Unit converting

Under weighing state, you can press [UNITS] to convert the display unit between “kg” and “lb” and at the same time the relevant cursor will appear.

Since the cursor indicating the unit is also regarded as a cursor indicating stability for weighing, the cursor indicating the unit will be on only when the

weighing is steady.

Note: Edition REV 1.0 has no unit converting function.

5.10. Digit Input

While carrying through calibration operation, you may need to input the digit. The digit input is all fulfilled via[←] and [↑] in cooperating. [←] refers to place- shifting key, it is used for selecting place the digit is at, and the digit selected place will flash. At this time if you press[↑], the flashing digit of the selected place will be changed in “0 → 1 → 2 …9 → 0” sequence.

For instance: How to input digit “001500”!

If the previous display content on the indicator is “030000”, the digit input steps are as follows:

Step 1: Press[←] once to make the indicator zero clearing, at this time the digit at the last right flashes and the indicator displays X0000"0".

Step 2: Press[←] once, the second digit at the last right flashes and X000"0"0 is displayed.

Step 3: Press[←] once, the third digit at the last right flashes and X00"0"00 is displayed.

Step 4: Press[↑] five times, the indicator displays X00"5"00 and “5” flashes.

Step 5: Press[←] once, the fourth digit at the last right flashes and X0"0"500 is displayed.

Step 6: Press[↑] once, the indicator displays X0"1"500 and “1” flashes.

Step 7: Press [TARE] to confirm.

Thus the input operation for a group of digit is completed. It is possible the “X” refers to a letter U or E.

6. Use Guide

6.1. Be sure that the ground terminal of AC power is properly grounded.

6.2. Weighing (tare included) can't exceed the scale's Max. capacity plus 9e (“e” refers to the division value). When the weighing is more than the value, the indicator displays “FULL”.

6.3. Never disassemble it without authorization.

6.4. If the indicator displays nothing or its display doesn't change after power-up, please try to turn off its power and turn it on again.

6.5. When you set “F1” and “F2” data, you may have not enough patient or make a mistake. If you don't intend to be a more professional personnel, you only need to make F1.6=2 and F2.5=2, thus you may not consider to select the

other data of “F1” and “F2” because at this time the indicator (scale) will automatically select the setup value of the products leaving the company.

6.6. Turn off power supply and pull out its power plug at once if it is out of order. Non-specialized manufacturer or non-professional staff can’t fix it without authorization, you can contact our selling agent in your area.

6.7. If you need to re-calibrate the indicator, do it after the indicator is turned on for 30 minutes in order to ensure its circuit in stable working state.

Caution: Never change its setup data presumptuously once that the indicator can normally be operated, unless the act is permitted by the laws.

7. Data Setting and Calibrating

The scale (indicator) is set 3 main directories on the modification interphase in order that the users can conveniently amend the functions and measurement data of the scale (indicator). The following are the name and content of 3 main directories:

F1: Function management

F2: Circumstance factor adjusting

F3: Calibration

- a. Before setting or calibrating, you should first open the indication and find the circuit shorter J1 and make it short connected as diagrammed in Figure 8:

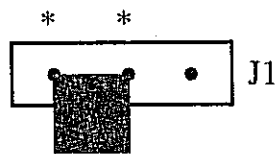

Figure 8: short connect the circuit shorter

- b. When setting or calibrating is finished, you should disconnect the circuit shorter as diagrammed in Figure 9:

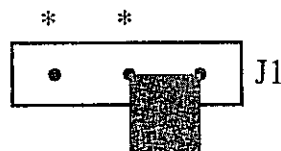

Figure 9: disconnect the circuit shorter

Note: If it displays “J1 ON”, it means you failed to disconnect the circuit shorter J1. You should disconnect it at once.

7.1. Entering main directories

Under turn-on state, pull out the power plug firstly to turn it off and then insert the plug and turn it on again. When the indicator is self-checking “7” → “0”, press [P] once (notice: you must operate the keys before the self-inspection is ended), the indicator displays SET UP . At this time if you press [→ 0 ←], the indicator will display F1 .

If it is in turn-off state, you should process the operation mentioned-above after it is turned on 30 minutes.

When you press [↑], the indicator will select the main directories in F1 → F2 → F3 → F1 sequence.

When you press [ENTER] the indicator will enter any subdirectory under the main directories.

When you press[EXIT] the indicator will return to the self-checking state of entrance.

7.2. Entering subdirectories and selecting

When the indicator displays “F1” or “F2” or “F3”, you can make it enter subdirectories by pressing [ENTER]. And you can make choices in the options of subdirectories by pressing [↑]. While pressing [EXIT], you can make the indicator withdraw the subdirectories.

7.2.1. Subdirectory F1

F1.1: Unit selecting, with 4 options

F1.1=1 only for choosing “kg” unit

F1.1=2 “kg” and “lb” unit choosing and converting. Its unit is automatically “kg” after turned on and it can be calibrated only under “kg” unit.

F1.1=3 “kg” and “lb” unit choosing and converting. Whenever turn-on, its unit is automatically “lb” and it can be calibrated only under “lb” unit.

F1.1=4 only for choosing “lb” unit

Note: You can only choose F1.1=1 when the version number is REV 1.0.

F1.2: Calibration mode selecting, with 3 options

F1.2=1 fixed point calibrating and only internal pre-set Max. capacity selecting

F1.2=2 arbitrary point calibrating and only internal pre-set Max. capacity selecting

F1.2=3 arbitrary point calibrating and arbitrary Max. capacity selecting

Note: You can only choose F1.2=3 when the version number is less than REV 2.0

F1.3: Baud rate selecting, with total 5 options

- F1.3=1 relevantly B=600
- F1.3=2 relevantly B=1200
- F1.3=3 relevantly B=2400
- F1.3=4 relevantly B=4800
- F1.3=5 relevantly B=9600

F1.4: Output mode, with 2 options

- F1.4=1 without command character in output data, i.e. state mark C is 20H (hex)
- F1.4=2 with command character in output data, i.e. state mark C is 28H (hex)
- F1.4=3 Serial output printing signal

F1.5 Beep selecting, with 2 options

- F1.5=0 switch-off beep
- F1.5=1 switch-on beep

F1.6: Selecting for setup value from F1.1 to F1.5, with 2 options

- F1.6=1 selection of setup value for the users
- F1.6=2 selection of setup value when the products leave the company, see the following table for the data.

Table 3

F1.1	F1.2	F1.3	F1.4	F1.5
1	3	2	1	1

Note: After last option F1.6 of F1 is finished, press [ENTER] to confirm, the indicator displays F2, which means the indicator (scale) enters the next main directory at this time.

When pressing [↑], you can re-select main directories. If you need to withdraw main directory, you should press [EXIT].

7.2.2. Subdirectory F2

F2.1: Turn-on zero range selecting, with 4 options

- F2.1=0 auto turn-on zero function canceling
- F2.1=5 turn-on zero range of 5% F•S
- F2.1=10 turn-on zero range of 10% F•S
- F2.1=20 turn-on zero range of 20% F•S

F2.2: Auto zero tracking range selecting, with 5 options

- F2.2=0.2 auto zero tracking range of 0.2e
- F2.2=0.5 auto zero tracking range of 0.5e

F2.2=1.0 auto zero tracking range of 1.0e

F2.2=2.0 auto zero tracking range of 2.0e

F2.2=3.0 auto zero tracking range of 3.0e

F2.3: Digit wave-filtering coefficient, with 3 options

F2.3=1 low-degree wave-filtering: Suitable for the conditions with weak air flow or little atmospheric pressure change

F2.3=2 medium-degree wave-filtering: Suitable for general occasion

F2.3=3 high-degree wave-filtering: Suitable for the situations with strong air flow or large atmospheric pressure change

F2.4: Extension display mode (i.e. internal graduation number display), with 2 options

F2.4=0 which means prohibiting extension display

F2.4=1 which means allowing extension display

Note: “extension display” refers to internal resolution ration display, you can use this method conveniently to adjust and view the error.

F2.5: Selecting for setup value from F2.1 to F2.4, with 2 options

F2.5=1 selection of setup value for the users

F2.5=2 selection of setup value when the products leave the company, see the following table for the data.

Table 4

F2.1	F2.2	F2.3	F2.4
20	0.5	2	0

7.2.3.Subdirectory F3

“F3” is used for carrying out calibration function.

7.3. Calibration

7.3.1. When the indicator display , press [ENTER] to make the indicator (scale) enter calibration function. At this time the indicator displays , and the digit at in the right is Min. display value. There are 3 options for the Min. display value, and the value is separately 1, 2 and 5.

7.3.2. After you select Min display value via [↑], and press [ENTER] to confirm.

If the version number is less then REV 2.0 , you should use the digit-input method to input the Max. capacity, the procedure are as follows:

- a. After the Min. display value is confirmed, the indicator displays

$UA_5A_4A_3A_2A_1A_0$, and “ $A_5A_4A_3A_2A_1A_0$ ” refers to the last input value in storage. If you need to change the value, you should press [←] to clear the display, i.e. make the indicator display $U0000$ “0” , and at this time the decimal point is disappear.

b. Input the Max. capacity you need according to the method on Item 5.10.

c. Press [P] and [ENTER] successively to make decimal point appear on second place at right, i.e. $UB_5B_4B_3B_2B_1B_0$, and “ $B_5B_4B_3B_2B_1B_0$ ” is the new value you input just now.

d. Press [←] to make decimal point move to the needed place.

If the version number is more then or equal to REV 2.0 , you can select the pre-set Max. capacity.

Under this case, the indicator displays 6 (12 under “lb” state). The value displayed represents Max. weighing capacity, and there are 13 options for Max. capacity, separately :

6kg (12lb), 15kg (30lb), 30kg (60lb), 60kg (120lb), 150kg (300lb), 300kg (600lb), 600kg (1200lb), 1000kg (2000lb), 1500kg (3000lb), 2000kg (4000lb), 3000kg (6000lb), 5000kg (10000lb), 10000kg (20000lb)

You can select Max. weighing capacity you need by pressing [↑].

Notice: The scale (indicator) is able to comprehend the graduation number automatically through the Min. display value and Max. capacity you select. And the graduation number range to be comprehend is always within in 2000~15000.

For instance:

when the Min. display value selected is 1 and the Max. capacity selected is 60kg, the graduation number to be accepted is 6000, neither 600 nor 60000. And when the Min. display value and the Max. capacity you select is separately 1 and 1000kg, the graduation number to be accepted is 10000, neither 1000 nor 100000.

7.3.3. After you press [ENTER] to confirm the Max. capacity, the indicator displays $SCL-09$ and carry through countdown, at this time it automatically confirm zero position.

7.3.4. After finishing the countdown, the indicator displays $SCL-00$. At this time after you press [ENTER], the display matter of the indicator has 2 possibilities.

a. When F1.2=1, it means the case you select is fixed point calibration.

At this time the indicator displays a weight data. See the following table for the relation between the weight data and the Max. capacity.

Table 5: Relation between the weight data and the Max. capacity.

Max. Capacity (kg/lb)	6 /12	15 /30	30 /60	60 /120	150 /300	300 /600	600 /1200	1000 /2000	1500 /3000	2000 /4000	3000 /6000	5000 /10000	10000 /20000
Display Value	5 /10	10 /20	20 /50	100 /200	200 /500	600 /1200	1000 /2000	3000 /5000					

At this moment you can load the standard weights (or substitute) equal to the weight displayed on the platform and then press [ENTER]. At this time the indicator will display **Add-09** and then carry through countdown. After the countdown is finished, the whole calibration is ended, the indicator displays **F3**. If pressing [EXIT], you can withdraw calibration.

b. When F1.2=2 or F1.2=3, it means the case you select is arbitrary point calibration.

At this time the indicator displays **Add-09**, under this state, you can load the weights on the platform and generally the weights loaded should be more than 30% Max. capacity so as to greatly increase the linearity degree. Press [←] to make the indicator display **E0000“0”**, and at this time the decimal point is presented at corresponding place and “0” at the last right flashes. Then input the data equal to the known weight by pressing [↑] and [←] in cooperating according to the method on Item 5.10 and press [ENTER] to confirm.

The indicator displays **Add-09** and carry through countdown, after the countdown is finished, the whole calibration is ended, and at this time the indicator displays **F3**. At this time, you should disconnect the circuit shorter (refer to Item b, on page 12)

Press [EXIT] (withdraw setup state) to make the indicator return to self-checking. After finishing the self-checking, the indicator enters normal display under weighing state.

Notice: If the version number is less than REV 2.0, you can only select arbitrary point calibration. If it display “J1 ON”, it means you failed to disconnect the circuit shorter J1. You should disconnect it at once.

7.4. Flow chart for setting and calibrating

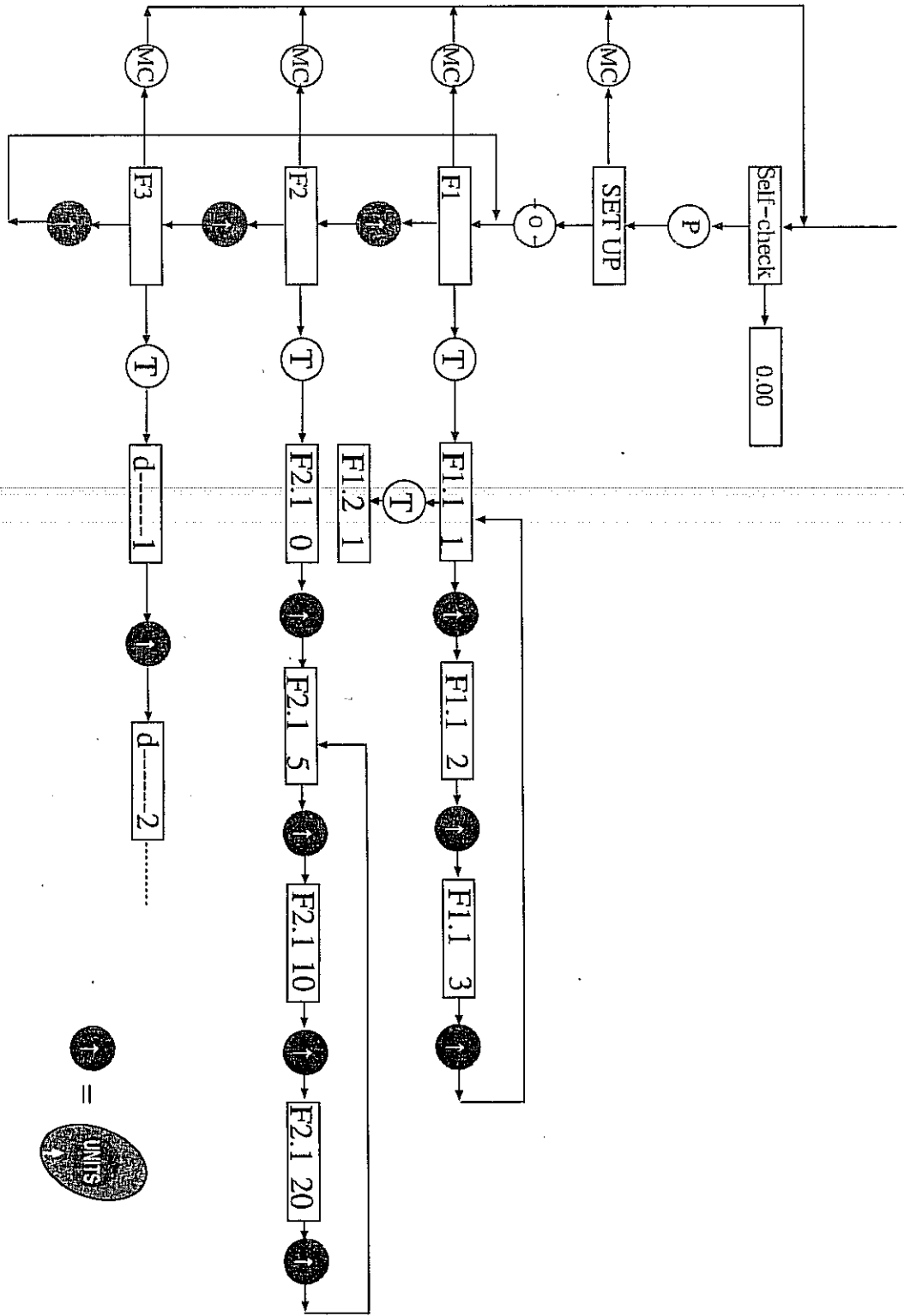

Figure 10-1: Entering setup state and selecting options of main directories and subdirectories by pressing

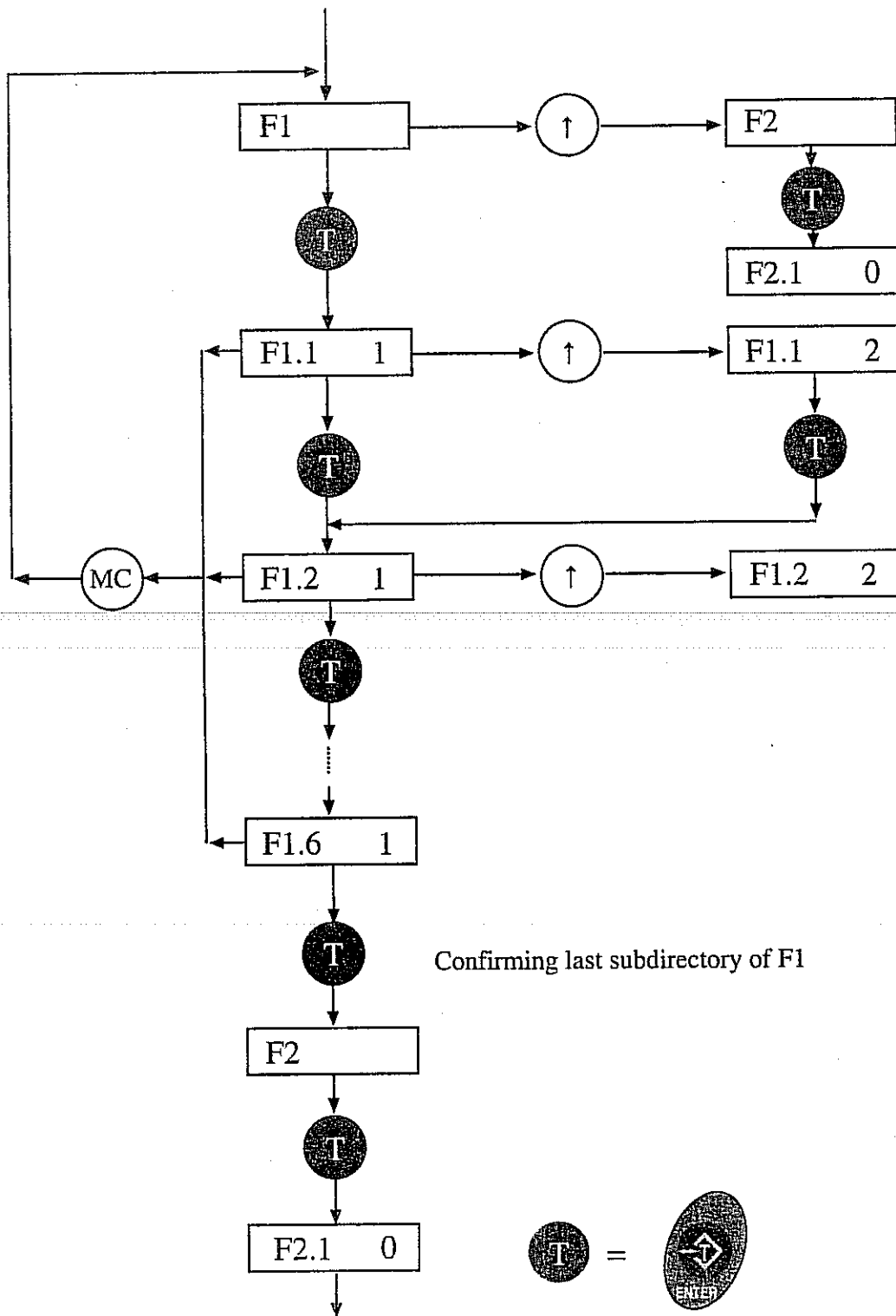

Figure 10-2: Entering subdirectories by **T**, entering the next main directory by confirming the last option of subdirectory

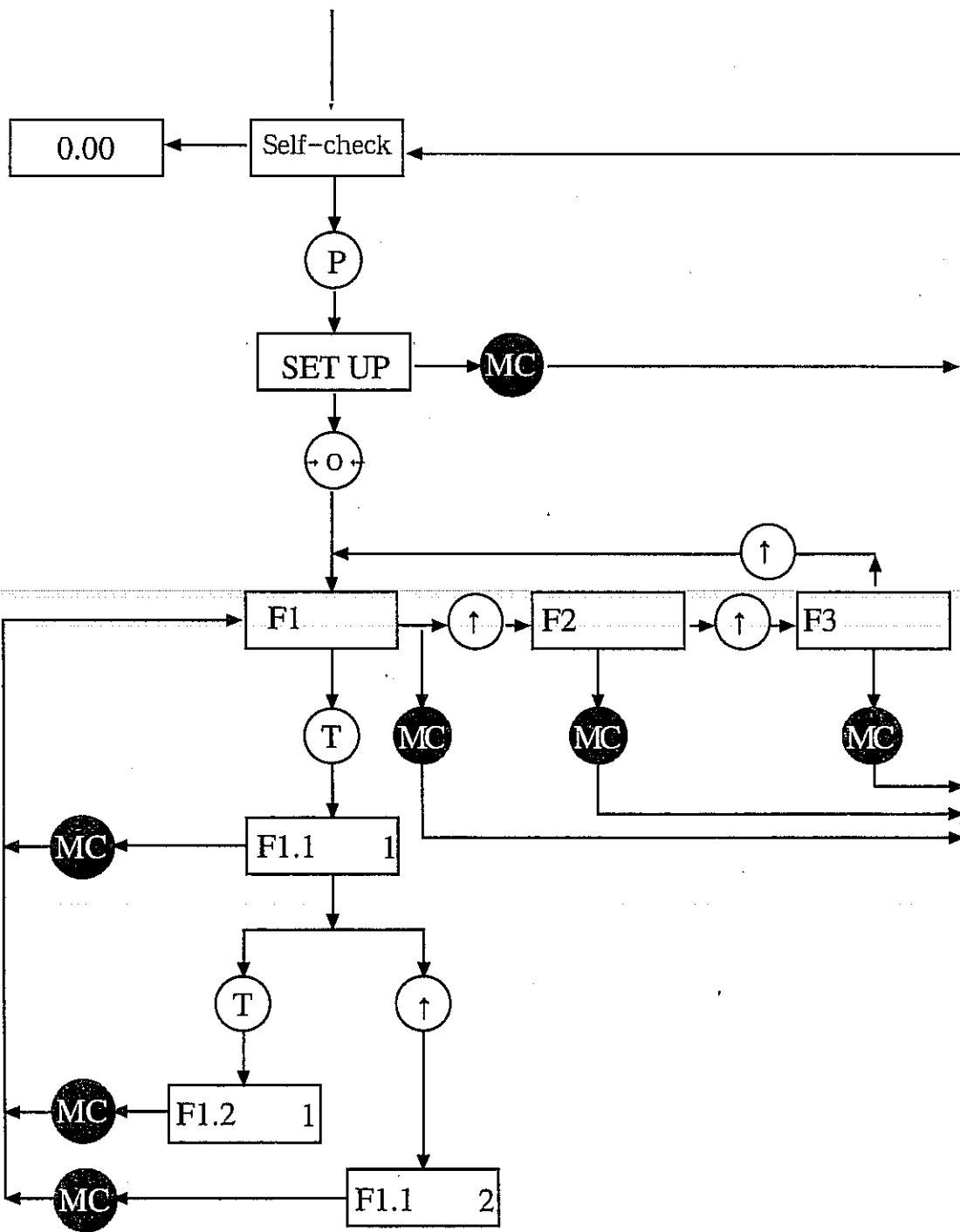

Figure 10-3: Withdrawing from main directory or returning to main directory from subdirectory by MC

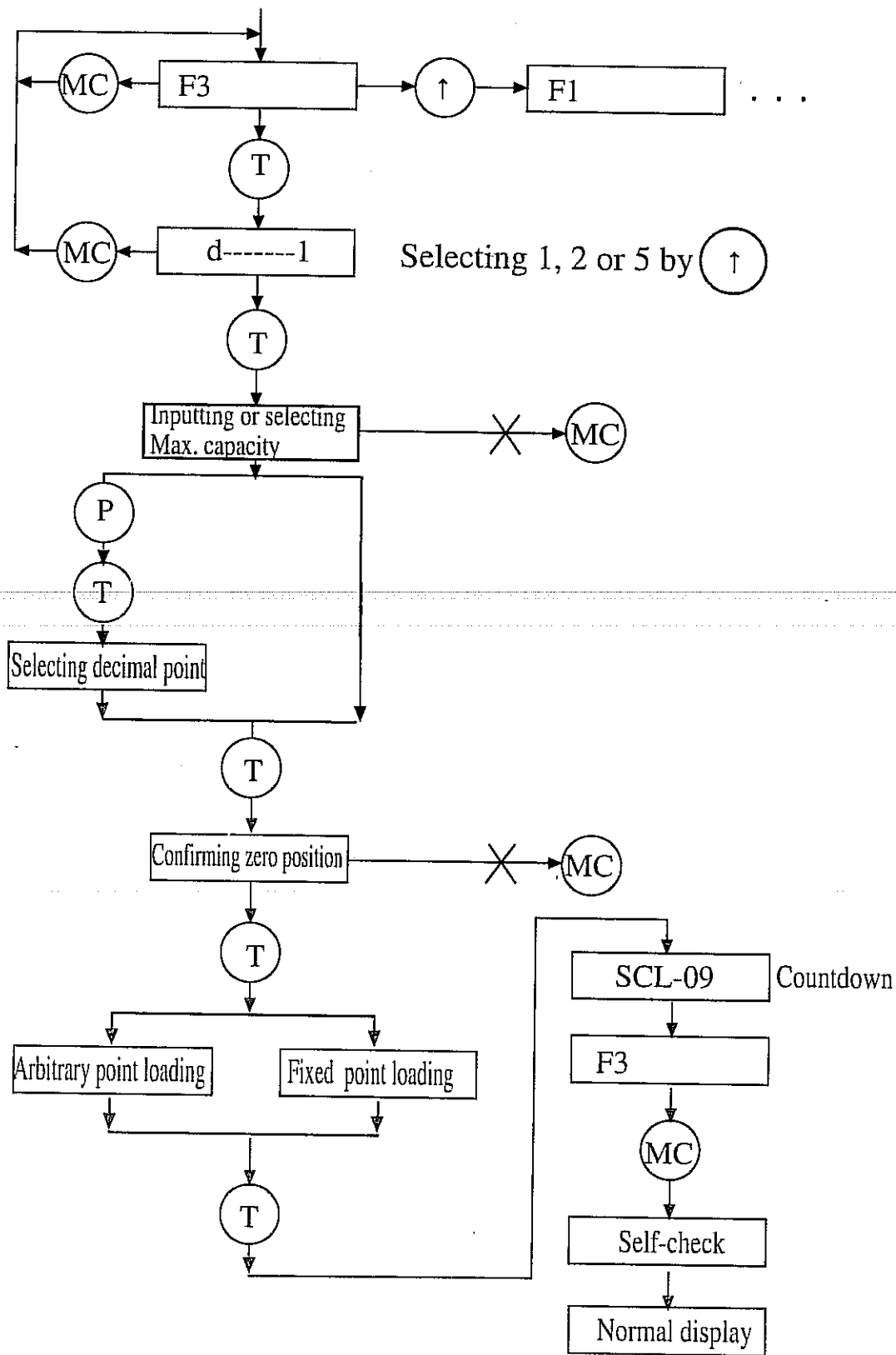

Figure 10-4 : Calibration flow